

Supplemental Instructions

Extension Spring Installation

This is a supplement to the **Residential Garage Door Instructions** (referred to as the MANUAL). It covers installation of extension springs (STEP 14 of the MANUAL). For all other information and safety warnings concerning your garage door, see the MANUAL. Read the information in both manuals before beginning installation.

Please read and understand these instructions completely before proceeding with the installation of extension springs. Carefully follow these instructions to avoid personal injury or property damage.











Use these instructions for extension springs only. Your spring hardware should match the list shown in Table EXT-1. If you are missing any spring hardware, call the Consumer Services 800# found on the front cover of the MANUAL.

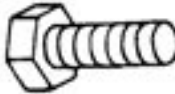

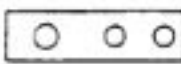
WARNING

Extension spring doors must never be operated without a properly installed spring containment cable.

Table EXT-1

DESCRIPTION	DOOR SIZE	QTY.
 EXTENSION SPRING	Single Car Doors 8' - 9' W X 7' H	2
	Double Car Doors 16' W X 7' H	2 or 4
 SHEAVE	Single Car Doors 8' - 9' W X 7' H	4
	Double Car Doors 16' W X 7' H	4
 SHEAVE FORK	Single Car Doors 8' - 9' W X 7' H	2
	Double Car Doors 16' W X 7' H	2 or 6
 3/8" X 1 1/4" SHEAVE BOLT	Single Car Doors 8' - 9' W X 7' H	4
	Double Car Doors 16' W X 7' H	4
 5/16" EYEBOLT	Single Car Doors 8' - 9' W X 7' H	2
	Double Car Doors 16' W X 7' H	2 or 4
 SAFETY SPRING CONTAINMENT KIT	Single Car Doors 8' - 9' W X 7' H	2
	Double Car Doors 16' W X 7' H	2 or 4
 (3) HOLE ADJUSTMENT KIT	Single Car Doors 8' - 9' W X 7' H	2
	Double Car Doors 16' W X 7' H	2
 YOKE PLATE	Single Car Doors 8' - 9' W X 7' H	0
	Double Car Doors 16' W X 7' H	0 or 2
 5/16" YOKE BOLT	Single Car Doors 8' - 9' W X 7' H	0
	Double Car Doors 16' W X 7' H	0 or 4
 S-HOOK	Single Car Doors 8' - 9' W X 7' H	2
	Double Car Doors 16' W X 7' H	2
 BLACK BUSHING	Single Car Doors 8' - 9' W X 7' H	2
	Double Car Doors 16' W X 7' H	2 or 4
 5/16" FLANGE NUT	Single Car Doors 8' - 9' W X 7' H	4
	Double Car Doors 16' W X 7' H	4 or 8
 3/8" FLANGE NUT	Single Car Doors 8' - 9' W X 7' H	4
	Double Car Doors 16' W X 7' H	4

Assembling and Installing Extension Springs

Step 1: Some doors will be supplied with two springs and some will have four. Assemble springs with sheaves on the floor. A 3/8" x 1-1/4" bolt and nut are used to attach the sheave. (FIG. EXT-1)

NOTE: If your door was supplied with four large extension springs, take notice of the color coding on the ends of the springs. If there are two color codes, be sure to use one of each on either side so that the spring tension is equal on both sides.

Step 2: Attach a sheave in the third hole on the angle approximately 4 inches from the wall on both sides. Use a 3/8" x 1-1/4" bolt, 3/8" washer and nut. The head of the bolt must be on the door side. (FIG. EXT-2)

Step 3: Attach the eye bolts with one 5/16" nut on each side of the rear hanger. The eyebolts should be about 12 inches above the track to keep the spring assembly from dragging on the track. The eyebolts can be as low as 4 inches above the track if you have space problems. Tighten the eyebolt nuts. (FIG. EXT-3)

Step 4: Carefully raise the door and prop it about halfway open. (FIG. EXT-4)



WARNING

This is the first time the new door is being opened. If the tracks are not correctly aligned or the back hangers are not strong enough the door may fall. Also, the door will be very heavy without the help of the springs. Have two or more people help you. Proceed slowly and carefully.

Check to be sure the horizontal tracks are parallel with each side of the door. With the door about halfway open, make sure the rollers do not come out of the top brackets more than about 1/2". If adjustment of the rear hangers is necessary, lower the door first because the weight of the door is supported by the rear hangers.

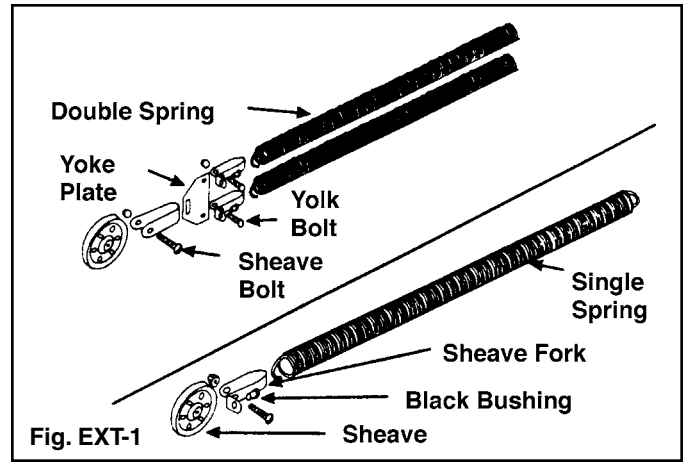

Fig. EXT-1

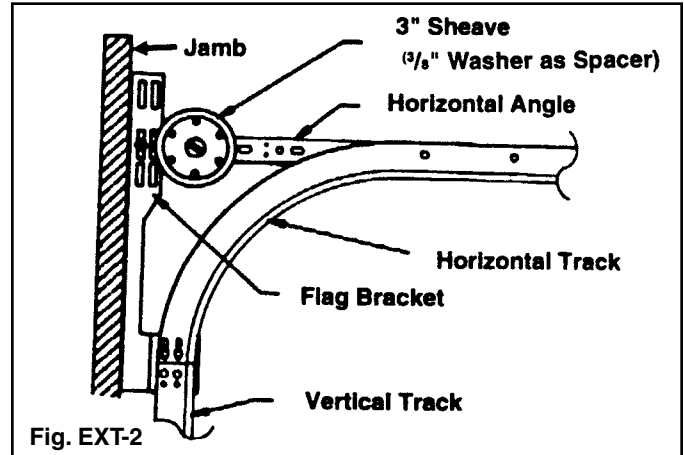

Fig. EXT-2

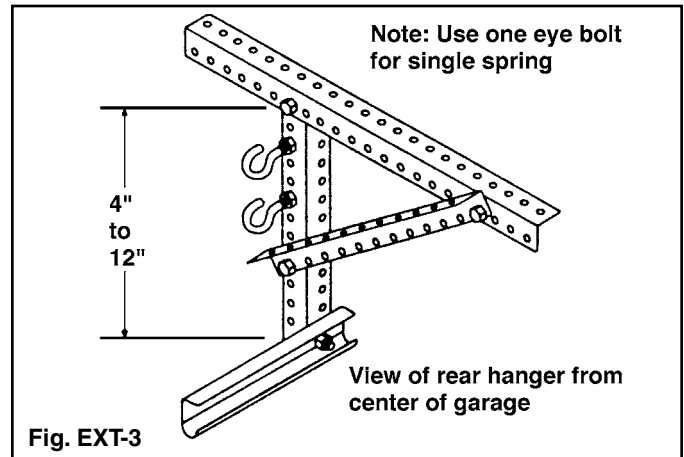

Fig. EXT-3

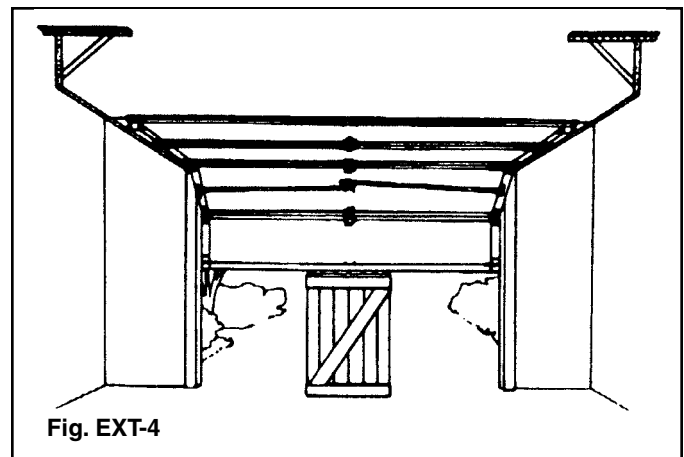

Fig. EXT-4

Step 5: Carefully raise the door to fully open position. Place "C" clamps on both sides of the track below the bottom rollers to keep the door from falling closed. (FIG. EXT-5)

Check again to be sure the horizontal tracks are parallel with the edges of the door. The rollers must not come out of the hinges or brackets.

Step 6: Hook the ends of the springs over the eyebolts at the rear track hangers.

Attach the loop of a cable over the button on the bottom bracket, if not done so already. Thread the cable up over the stationary sheave. (FIG. EXT-6)

Continue the cable over and around the sheave on the springs. (FIG. EXT-7)

Step 7: Tie the cable to the three hole adjusting clip exactly as shown in Fig. EXT-8A. Hook the cable to the horizontal angle with an "S" hook. Adjust the knot at the three hole adjusting clip. Adjust so that all spring tension is relieved and the cable holds the springs above the horizontal track. The springs should be stretched the same on both sides of the door. (FIG. EXT-8A)

Important: Attach the warning tag found in the white envelope with orange print to the spring assembly (this tag may already be attached). (FIG. EXT-9)

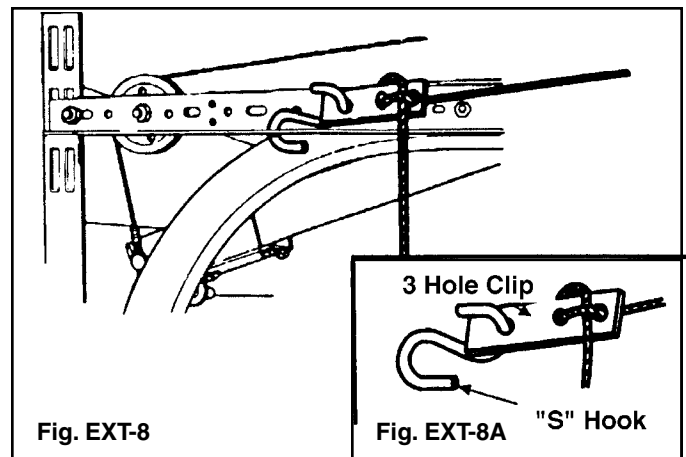
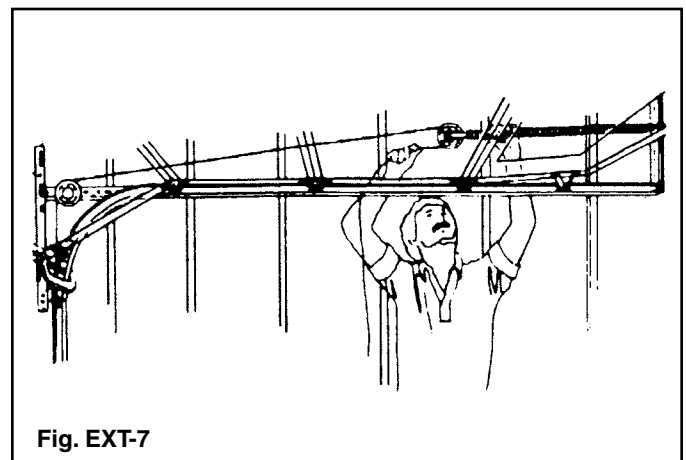
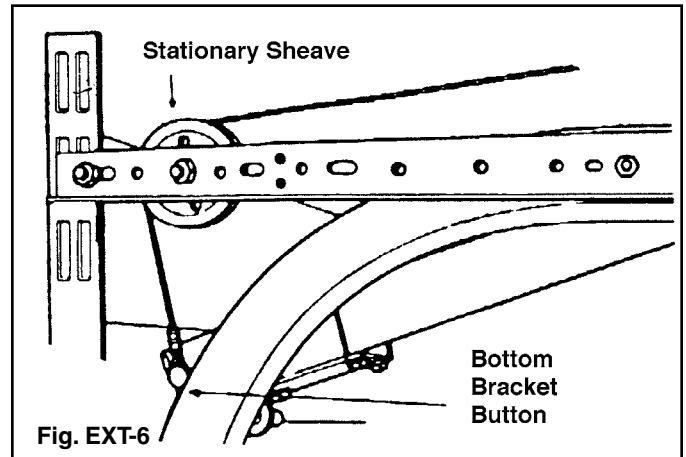
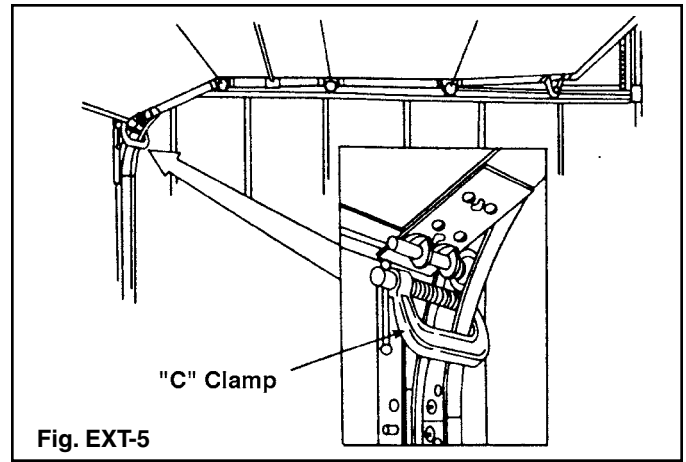

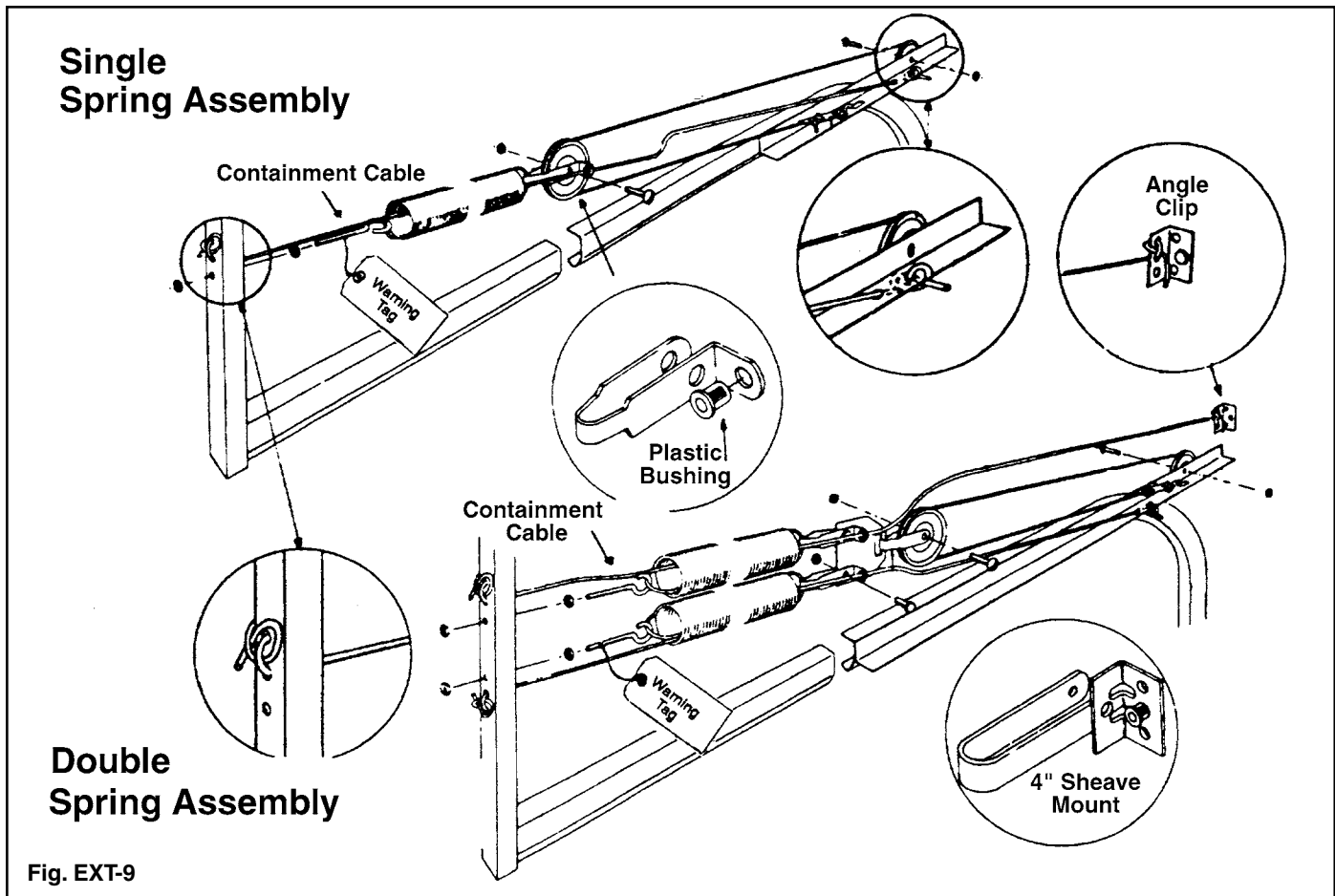

Fig. EXT-9

Installing Safety Containment Kit



WARNING

Garage door extension springs can cause serious injury and property damage if they break under tension and are not secured with safety cables. Do not neglect the following step.

Step 8: Tie one end of the 1/8" containment cable to the rear track hangers. Tie the cable as shown in the illustration (FIG. EXT-9). Thread the cable through the center of the extension spring and through the bushing in the sheave fork. Tie the remaining end to the horizontal angle as shown. This must be done for each of the springs.

NOTE: If your door has four extension springs, tie the upper containment cable to an angle clip mounted to the jamb. (FIG. EXT-9)

To adjust extension spring tension, use two "C" clamps to carefully clamp the door in the open position. Tension can be changed by moving the "S" hooks to different holes in the horizontal track angles or by adjusting the cable in the three hole clip. Both sides must be adjusted equally. Moving the hooks closer to the door opening increases tension.

Tension can also be adjusted slightly by releasing spring tension and relocating the eyebolts higher on the track hanger. When reinstalling, the higher the eyebolt, the greater the tension.



WARNING

Use extreme care when readjusting extension springs and make sure that the door is carefully secured by "C" clamps in the open position before you begin. When the door is closed, the springs and mounting hardware are under extreme tension and are potentially dangerous.